

# AQUASONIC™ WATER-ATOMIZING FIRE SUPPRESSION SYSTEM

Data/Specifications



## FEATURES

- FM Approved
- Effective suppression of Class B combustibles (i.e. flammable liquids, oils, greases, tars, oil-based paints, lacquers and flammable vapors)
- Environmentally safe
- Fully self-contained
- Minimal water discharge
- Optimized protected volume with minimal piping and system discharge devices
- Flexible system piping and atomizer location

## APPLICATION

The AQUASONIC™ Water-Atomizing Fire Suppression System utilizes water droplets as the suppression agent. These droplets can effectively be applied in total flooding fire suppression applications having a free volume up to and including 9200 ft<sup>3</sup> (260 m<sup>3</sup>). Applications include:

- Machinery Spaces
- Both Insulated and Non-Insulated Combustion Turbine Enclosures
- Generator Enclosures
- Flammable Liquid Storage

**Note:** Non-acceptable hazards include rack or palletized storage of flammable or combustible liquids.

## PRINCIPLES OF OPERATION

The AQUASONIC System suppresses a Class B fire by causing one or more of the following reactions:

- Heat extraction from the fire as water is converted into vapor and the fuel is cooled
- Dilution of flammable vapors by the entrainment of water vapor
- Cooling of liquid hydrocarbon fuels below vaporization temperature

When a fire condition is detected in the protected hazard, the detection and control system will actuate the AQUASONIC System which contains nitrogen cylinders and a water tank. The nitrogen storage cylinders provide pressure to drive the water to the system atomizers. When the system is operated, quick-opening valves on the nitrogen cylinders open and the gas pressure flows through pressure regulators which maintain the pressure at 125 psi (8.6 bar). This pressure drives the water through the opened water valve and to the system atomizers. The nitrogen discharge also provides the necessary pressure to create the water discharge plume.

**Note:** Water-atomizing systems shall not be used for direct application to materials that react with water to produce violent reactions or significant amounts of hazardous products. Such materials include the following:

- Reactive metals such as lithium, sodium, potassium, magnesium, titanium, zirconium, uranium, and plutonium
- Metal alkoxides, such as sodium methoxide
- Metal amides, such as sodium amide
- Carbides, such as calcium carbide
- Halides, such as benzoyl chloride and aluminum chloride
- Hydrides, such as lithium aluminum hydride
- Oxyhalides, such as phosphorus oxybromide
- Silanes, such as trichloromethylsilane
- Sulfides, such as phosphorus pentasulfide
- Cyanates, such as methylisocyanate

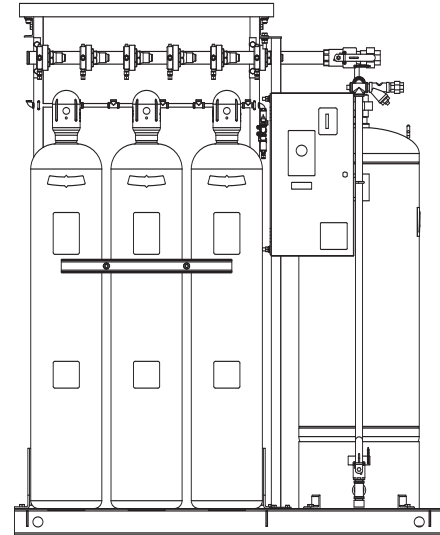

007888

## DESCRIPTION

The AQUASONIC Water-Atomizing Fire Suppression System is a total flood system designed to protect Class B flammable liquid hazards in machinery spaces, both insulated and non-insulated combustion turbine enclosures, generator enclosures, and flammable liquid storage. The AQUASONIC system can protect a potential hazard with a free volume up to 9200 ft<sup>3</sup> (260 m<sup>3</sup>) with two (2) atomizers that use low pressure, dual flow, supersonic atomization technology to create a minimum 10-minute discharge plume of water droplets that are the optimum size to suppress a Class B fire. When sprayed within an enclosure, the AQUASONIC Atomizer spray pattern expands slightly and the water droplets are primarily distributed (circulated) around the space via the high velocity atomizing media discharge. As the high velocity discharge plume of water droplets approaches the floor, or other horizontal obstruction, a large majority of the plume is diverted laterally, as well as vertically upwards, to fill the spaces between the core spray patterns and above the atomizers. The circulation characteristics of the AQUASONIC Atomizer plume result in rapid, homogenous distribution of water droplets throughout the protected environment. The AQUASONIC System has been fire tested within compartmentalized areas and found effective for the suppression of a wide variety of exposed and shielded Class B hydrocarbon pool, spray, and cascading pool fires.

## DESCRIPTION (Continued)

The system is capable of automatic detection and actuation and/or remote manual actuation.

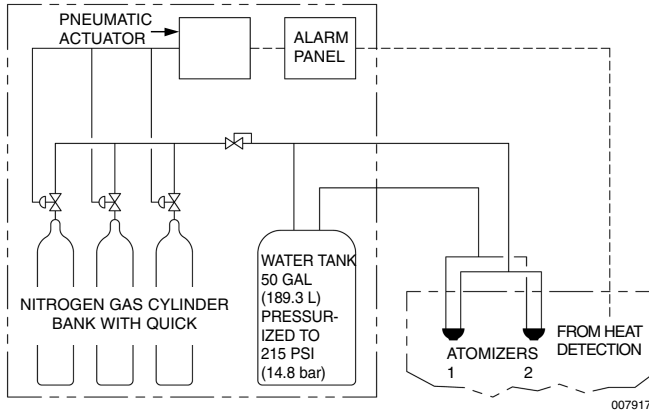

The above figure provides a system schematic. The engineered AQUASONIC System provides a less complex alternative to high pressure water mist systems. It is primarily comprised of a pre-packaged AQUASONIC Supply Skid containing both compressed nitrogen and stored water which upon actuation automatically supplies the necessary quantity of each to the AQUASONIC Atomizers.

A system installation and maintenance manual is available containing information on system components and procedures concerning design, operation, inspection, maintenance, and recharge.

The system is installed and serviced by authorized ANSUL distributors that are trained by the manufacturer.

## COMPONENTS

**AUTOPULSE® Control System** – The AUTOPULSE Control system is designed to monitor fixed fire hazards. The control system can automatically actuate the AQUASONIC system after receiving an input signal from one or more initiating devices, i.e. manual pull station or detector. The control system incorporates an internal power supply, on-line emergency batteries, and solid state electronics.

**ANSUL AUTOMAN® II-C Releasing Device** – The ANSUL AUTOMAN II-C Releasing Device consists of a metal enclosure which contains a spring-loaded puncture pin release mechanism, an actuation cartridge, electrical circuitry, and an input/output terminal strip for making electrical connections. The ANSUL AUTOMAN II-C releasing device provides automatic pneumatic actuation of the AQUASONIC System. When wired to an AUTOPULSE Control System, it will provide supervised electric detection and release. It also provides manual actuation using the strike button on the release enclosure and with optional remote manual cable pull station. When an AUTOPULSE Control System is used, manual actuation is accomplished using an electric manual pull station. The ANSUL AUTOMAN II-C Releasing Device requires an LT-10-R nitrogen cartridge for system actuation. Cartridge must be ordered separately.

**Remote Actuator (Optional)** – The Remote Actuator is a device that allows for system actuation from a location either on or away from the AQUASONIC skid assembly. The actuator contains an LT-10-R nitrogen cartridge; when actuated, it will supply pressure to the quick-opening valves on the skid unit, allowing nitrogen to flow through the system.

**50 Gallon Water Tank Assembly** – The AQUASONIC System agent tank is a 50 gal (189.3 L) capacity water tank featuring a 0.17 in. (4.3 mm) thick ASME pressure vessel that is certified to 215 psi (14.8 bar). The tank features a 2 in. (5.1 cm) fill opening; the tank also has an outlet that is positioned for optimal flow, containing a Y strainer to stop any foreign particles in the water stream from reaching the Atomizer(s). The tank is internally coated with a black two-part epoxy primer which serves as a rust inhibitor.

**Quick-Opening Valve and Cylinder Assembly** – The AQUASONIC skid assembly contains multiple 3AA 2400 DOT rated 400 ft<sup>3</sup> (11.3 m<sup>3</sup>) nitrogen cylinder assemblies. Each cylinder assembly contains a quick-opening valve and actuator. When the actuation pressure reaches the nitrogen actuation line to the cylinder assembly, the piston on the quick-opening valve actuator forces the lever of the valve to the open position, allowing nitrogen to flow through the system.

**Regulator** – The AQUASONIC skid assembly contains a regulator for each of the nitrogen cylinders. Each regulator is factory set at 125 psi (8.6 bar), allowing the proper nitrogen pressure to discharge the water from the tank to the atomizer. It also allows the necessary nitrogen pressure to flow directly to the atomizer to activate its supersonic atomization technology.

**Atomizer** – The AQUASONIC Atomizer utilizes patented supersonic technology, combining separate feeds of compressed nitrogen gas and water to generate and uniformly distribute water droplets throughout a protected volume. Each atomizer is delivered pre-trimmed with the appropriate water flow control orifice, strainer, mounting plate, and dust cap in place. The water supply inlet is 1/2 in. NPT, and the nitrogen supply inlet is 1 in. NPT. The AQUASONIC Atomizer utilizes an in-line restricting orifice to generate the appropriate water flow.

**Note:** When ordering an AQUASONIC system, the Atomizer Assembly must be specified.



## APPROVALS/STANDARDS

**Applicable Standards** – The AQUASONIC Water-Atomizing Fire Suppression System complies with NFPA 750 (2006) "Standard on Water Mist Fire Protection Systems."

FM Approved

## INSTALLATIONS

All system components and accessories must be installed by personnel trained by the manufacturer. All installations must be performed according to the guidelines stated in the manufacturer's design, installation, operation, inspection, recharge, and maintenance manual and NFPA 750.

## AVAILABILITY AND COST

**Availability** – AQUASONIC Water-Atomizing Fire Suppression Systems are sold and serviced through a network of independent distributors located in most states and many foreign countries.

**Cost** – Cost varies with type of system specified, size and design.

## TECHNICAL SERVICES

For information on the proper design and installation, contact a local authorized AQUASONIC System distributor. The ANSUL Technical Services Department is also available to answer design and installation questions. Call 800-TO-ANSUL (862-6785) or 715-735-7415.

## ORDERING INFORMATION

Weight Part No.	Description	Shipping	
		lb	(kg)
17728	ANSUL AUTOMAN II-C Releasing Device Shipping Assembly	26	(11.8)
423423	LT-10-R Nitrogen Cartridge Shipping Assembly	2	(1.0)
26310	Cocking Lever	1	(0.5)
30595	Remote Actuator Shipping Assembly	8	(3.6)
11160	Quick-Opening Valve Actuator	2	(1.0)
31059	400 ft <sup>3</sup> (11.3 m <sup>3</sup> ) N <sub>2</sub> Cylinder with Quick-Opening Valve	216	(98.0)
472014	Regulator	3	(1.4)
435877	Atomizer Shipping Assembly, including Restriction Orifice 0.092 in. (2.34 mm), Pressure Range 66-80 psi (4.6-5.5 bar)	19	(8.6)
435878	Atomizer Shipping Assembly, including Restriction Orifice 0.088 in. (2.24 mm), Pressure Range 81-95 psi (5.6-6.6 bar)	19	(8.6)
435879	Atomizer Shipping Assembly, including Restriction Orifice 0.084 in. (2.13 mm), Pressure Range 96-115 psi (6.7-7.9 bar)	19	(8.6)
435880	Atomizer Shipping Assembly, including Restriction Orifice 0.080 in. (2.03 mm), Pressure Range 116-140 psi (8.0-9.7 bar)	19	(8.6)

## SPECIFICATIONS

An ANSUL AQUASONIC Water-Atomizing Fire Suppression System shall be furnished.

### 1.0 GENERAL

#### 1.1 References

- 1.1.1 Factory Mutual (FM)
- 1.1.2 National Fire Protection Association (NFPA)
  - 1.1.2.1 NFPA 750

#### 1.2 Submittals

- 1.2.1 Submit two sets of manufacturer's data sheets
- 1.2.2 Submit two sets of piping design drawings

#### 1.3 System Description

- 1.3.1 The system shall be an automatic fire suppression system using patented supersonic technology for Class B combustibles
- 1.3.2 The system shall be capable of suppressing fires in the following areas: machinery spaces, both insulated and non-insulated combustion turbine enclosures, generator enclosures, and flammable liquid storage.
- 1.3.3 The system shall be an engineered type with a self-contained supply skid. The system design shall require limits set by the manufacturer and require that the final piping design be established utilizing calculations stated in the manufacturer's design manual. All design limitations shall be approved by Factory Mutual (FM).
- 1.3.4 The system shall be installed and serviced by personnel trained by the manufacturer.
- 1.3.5 The system shall be capable of protecting machinery spaces by utilizing total flooding application.

#### 1.4 Quality Control

- 1.4.1 Manufacturer: The AQUASONIC Water-Atomizing Fire Suppression System shall be manufactured by a company with at least thirty years experience in the design and manufacture of engineered fire suppression systems. The manufacturer shall be ISO 9001 registered.

#### 1.5 Warranty, Disclaimer, and Limitations

- 1.5.1 The engineered water-atomizing fire suppression system components shall be warranted for five years from date of delivery against defects in workmanship and material.

#### 1.6 Delivery

- 1.6.1 Packaging: All system components shall be securely packaged to provide protection during shipment.

#### 1.7 Environmental Conditions

- 1.7.1 The AQUASONIC system shall be capable of operating in a temperature range of 40 °F (4 °C) to 130 °F (54 °C).

**2.0 PRODUCT****2.1 Manufacturer**

- 2.1.1 Ansul Incorporated, One Stanton Street, Marinette, Wisconsin 54143-2542, Telephone (715) 735-7411.

**2.2 Components**

- 2.2.1 The system shall consist of an AUTOPULSE Control system which is designed to monitor fixed fire hazards. The control system can automatically actuate the AQUASONIC system after receiving an input signal from one or more initiating devices, i.e. manual pull station or detector. The control system incorporates an internal power supply, on-line emergency batteries, and solid state electronics.
- 2.2.2 The ANSUL AUTOMAN II-C Releasing Device shall consist of a metal enclosure which contains a spring-loaded puncture pin release mechanism, an actuation cartridge, electrical circuitry, and an input/output terminal strip for making electrical connections. The ANSUL AUTOMAN II-C releasing device shall provide automatic pneumatic actuation of the AQUASONIC System. When wired to an AUTOPULSE Control System, it shall provide supervised electric detection and release. It also provides manual actuation using the strike button on the release enclosure and with optional remote manual cable pull station. When an AUTOPULSE Control System is used, manual actuation shall be accomplished using an electric manual pull station. The ANSUL AUTOMAN II-C Releasing Device requires an LT-10-R nitrogen cartridge for system actuation.
- 2.2.3 Remote Actuator: The Remote Actuator shall allow for system actuation from a location either on or away from the AQUASONIC skid assembly. The actuator shall contain an LT-10-R nitrogen cartridge; when actuated, it will supply pressure to the quick-opening valves on the skid unit, allowing nitrogen pressure to flow through the system.
- 2.2.4 Agent Tank: The AQUASONIC System agent tank shall be a 50 gal (189.3 L) capacity water tank featuring a 0.17 in. (4.3 mm) thick ASME pressure vessel that is certified to 215 psi (14.8 bar). The tank shall feature a 2 in. (5.1 cm) fill opening; the tank also has an outlet that is positioned for optimal flow, containing a Y strainer to stop any foreign particles in the water stream from reaching the atomizer(s). The tank shall be internally coated with a black two-part epoxy primer which serves as a rust inhibitor.
- 2.2.5 Quick-Opening Valve and Cylinder Assembly: The AQUASONIC skid assembly shall contain multiple 3AA 2400 DOT rated 400 ft<sup>3</sup> (11.3 m<sup>3</sup>) nitrogen cylinder assemblies. The cylinder assembly shall contain a quick-opening valve and actuator. When the actuation pressure reaches the cylinder assembly, the piston on the quick-opening valve actuator forces the lever of the valve to the open position, allowing nitrogen to flow through the system.
- 2.2.6 Regulator: The AQUASONIC skid assembly shall contain a regulator for each of the nitrogen cylinders. Each regulator shall be factory set at 125 psi (8.6 bar), allowing the proper nitrogen pressure to discharge the water from the tank to the atomizer. It also allows the necessary nitrogen to flow directly to the atomizer to activate its supersonic atomization technology.
- 2.2.7 Atomizer: The AQUASONIC Atomizer shall utilize patented supersonic technology, combining separate feeds of compressed nitrogen gas and water to generate and uniformly distribute water droplets throughout a protected volume. Each atomizer shall be delivered pre-trimmed with the appropriate water flow control orifice, strainer, mounting plate, and dust cap in place. The water supply inlet shall be 1/2 in. NPT, and the nitrogen supply inlet 1 in. NPT. The AQUASONIC Atomizer utilizes an in-line restricting orifice to generate the appropriate water flow.

**3.0 IMPLEMENTATION****3.1 Installation**

- 3.1.1 The AQUASONIC Water-Atomizing Fire Suppression System shall be designed, installed, inspected, maintained, and recharged in accordance with the manufacturer's listed instruction manual and NFPA 750.

**3.2 Training**

- 3.2.1 Training shall be conducted by representatives of the manufacturer.